



AIRCHARGER™ HIGH-FLOW INTAKE KITS

INSTALLATION INSTRUCTIONS

63-3074 CHEVROLET 2010 Camaro ss V8-6.2L

NOTE: This kit was not designed to fit vehicles with a body lift.

TOOLS NEEDED:

Ratchet
Extension
13mm socket
10mm socket
Flat blade screw driver
Phillips screw driver
4mm allen wrench
3mm allen wrench

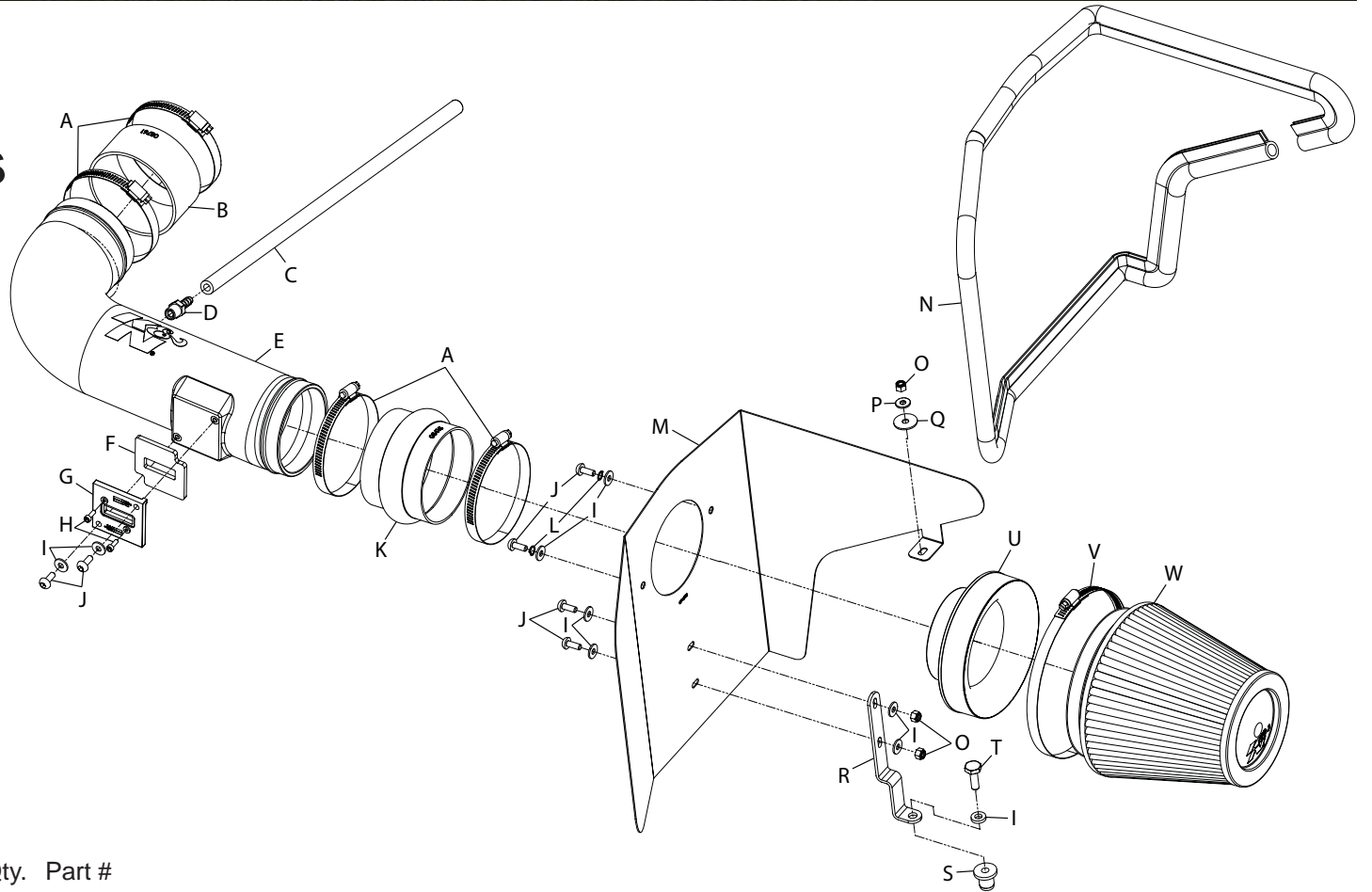

PARTS LIST:

| Description | Qty. | Part # | Description | Qty. | Part # | Description | Qty. | Part # |
|-------------------------------------|------|--------|----------------------------------|------|--------|-------------------------------------|------|---------|
| A Hose Clamp #64 Stainless | 4 | 08645 | I Washer; 6MM Flat, SS | 9 | 08269 | Q Washer; 1" X .300 X .100 Rubber | 1 | 21685 |
| B Hose; 4" ID X 2" L | 1 | 08761 | J Bolt; M6 X 1.00 X 16MM , Btnhd | 6 | 07730 | R Bracket; "Z", 63-3074, STL, TK/PC | 1 | 083126 |
| C Hose; 8MM ID X 21" L | 1 | 08409 | K Hose; 4" ID X 3" L Hump | 1 | 08418 | S Insert; 5/16-18 X .600 OD X .730L | 1 | 088002 |
| D Vent; STRT, 5/16" Barbed, 1/4 NPT | 1 | 08908 | L Washer; 1/4" Lock, ZN | 2 | 08198 | T Bolt; 5/16"- 18 X 1"L,SS | 1 | 07777 |
| E Intake Tube | 1 | 087232 | M Heat Shield | 1 | 074053 | U Adaptor; 57-3058 #454 | 1 | 27300 |
| F Gasket; 3/16 Poron | 1 | 09069 | N Edge Trim (70") | 1 | 102454 | V Hose Clamp # 104 | 1 | 08697 |
| G Adaptor; Nylon 6/6 GF, | 1 | 21515 | O Nut; 6MM Nylock, Hex | 3 | 07512 | W Air Filter | 1 | RF-1042 |
| H Bolt; M4 - 0.07 8MM, A/H CAP, SS | 2 | 07733 | P Washer; 5/16"ID X 5/8"OD, Flat | 1 | 08276 | | | |

NOTE: FAILURE TO FOLLOW INSTALLATION INSTRUCTIONS AND NOT USING THE PROVIDED HARDWARE MAY DAMAGE THE INTAKE TUBE, THROTTLE BODY AND ENGINE.

TO START:

- Turn off the ignition and disconnect the negative battery cable.
NOTE: Disconnecting the negative battery cable erases pre-programmed electronic memories. Write down all memory settings before disconnecting the negative battery cable. Some radios will require an anti-theft code to be entered after the battery is reconnected. The anti-theft code is typically supplied with your owner's manual. In the event your vehicles' anti-theft code cannot be recovered, contact an authorized dealership to obtain your vehicles anti-theft code.



- Disconnect the mass air sensor electrical connection.



- Remove the oil filler cap and then lift up and remove the engine cover. Reinstall the oil filler cap.



- Disconnect the crank case vent tube from the intake resonator as shown.



- Loosen the hose clamps which secure the stock intake tube to the air box and throttle body.



- Remove the stock intake tube as shown.



- Rotate the crank case vent tube 180°, then release the retainer at the valve cover port and then remove the crank case vent tube from the valve cover port.



- Remove the two air box retaining nuts shown.



- Lift up and remove the air box from the vehicle.
NOTE: K&N Engineering, Inc., recommends that customers do not discard factory air intake.



10. Remove the air box mounting grommet shown from the frame rail.

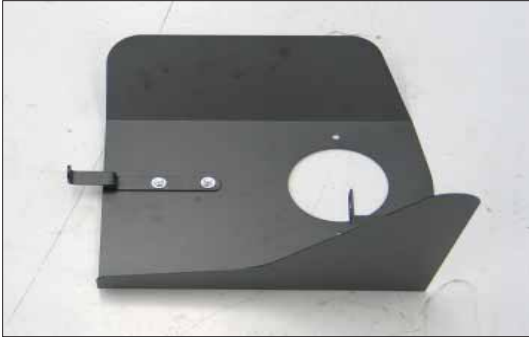

11. Install the heat shield mounting bracket (083126) onto the heat shield as shown using the provided hardware.

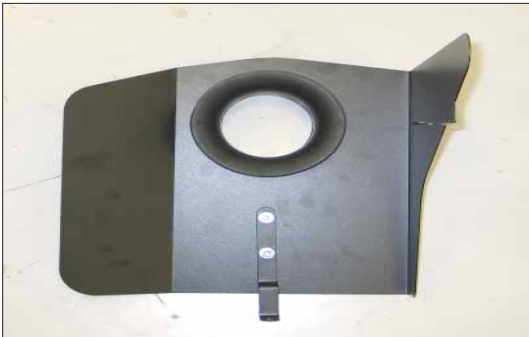

12. Install the filter adapter onto the heat shield and secure with the provided hardware.



13. Install the edge trim onto the heat shield as shown.

NOTE: Some trimming of the edge trim will be necessary.



14. Install the inserted nut onto the heat shield mounting bracket using the provided hardware. Do not completely tighten at this time.



15. Install the heat shield assembly into the vehicle so the inserted nut goes into the air box mounting grommet hole and the tab goes onto the air box mounting stud. Secure the heat shield with the provided hardware.



16. Install the silicone hose (08761) onto the throttle body and secure with the provided hose clamp.



17. Install the silicone hose (08418) onto the filter adapter and secure with the provided hose clamp.



18. Remove the two screws and then remove the mass air sensor from the factory air box.



19. Install the provided gasket onto the mass air sensor adapter as shown.



20. Install the mass air sensor into the adapter and secure with the provided hardware.

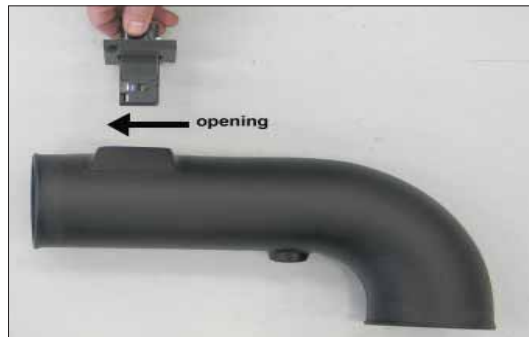

21. Install the mass air sensor assembly into the K&N intake tube and secure with the provided hardware.

NOTE: Be sure to place the mass air sensor with the opening pointed towards the filter end of the tube.



22. Install the provided 1/4npt fitting into the K&N intake tube as shown.



23. Install the K&N intake tube assembly into the silicone hose at the filter adapter and then into the silicone hose at the throttle body and secure with the provided hose clamps.



24. Attach the provided crank case vent hose to the 1/4npt fitting and then attach the open end to the vent port on the valve cover.



25. Install the K&N air filter onto the filter adapter and secure with the provided hose clamp.



26. Reconnect the mass air sensor electrical connection.



27. Reinstall the engine cover.



28. Reconnect the vehicle's negative battery cable. Double check to make sure everything is tight and properly positioned before starting the vehicle.

29. It will be necessary for all K&N® high flow intake systems to be checked periodically for realignment, clearance and tightening of all connections. Failure to follow the above instructions or proper maintenance may void warranty.

ROAD TESTING:

1. Start the engine with the transmission in neutral or park, and the parking brake engaged. Listen for air leaks or odd noises. For air leaks secure hoses and connections. For odd noises, find cause and repair before proceeding. This kit will function identically to the factory system except for being louder and much more responsive.

2. Test drive the vehicle. Listen for odd noises or rattles and fix as necessary.

3. If road test is fine, you can now enjoy the added power and performance from your kit.

4. K&N Engineering, Inc., suggests checking the air filter element periodically for excessive dirt build-up. When the element becomes covered in dirt (or once a year), service it according to the instructions on the Recharger® service kit, part number 99-5050 or 99-5000.

* FREE K&N® decal To register your warranty, please see us online at knfilters.com/register. FREE K&N® decal *

• 1455 CITRUS ST., P.O. BOX 1329, RIVERSIDE, CA., U.S.A. 92502 • TECH SERVICE 800-858-3333 • FAX 951-826-4001
• e-mail: tech@knfilters.com • WWW: <http://www.knfilters.com>

18886
12/4/09