



# AIRCHARGER™ HIGH-FLOW INTAKE KITS



## INSTALLATION INSTRUCTIONS

### 63-3075 CHEVROLET 2010 Camaro V6-3.6L

#### TOOLS NEEDED:

- Ratchet
- Extension
- 1/2" socket
- 10mm socket
- Flat blade screw driver
- T20 TORX
- 5/8" wrench
- 10mm wrench
- 4mm allen
- 2.5mm allen

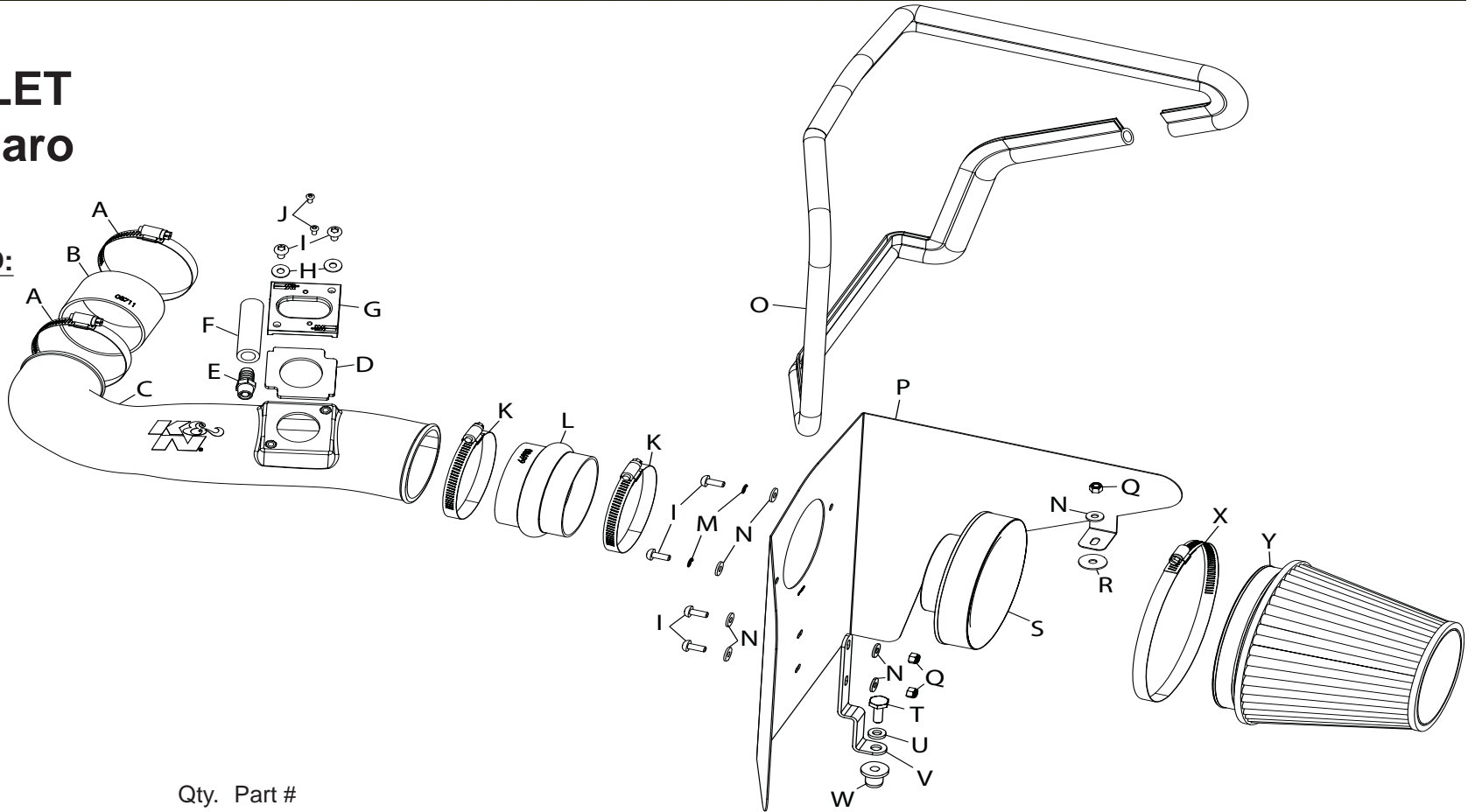

#### PARTS LIST:

Description	Qty.	Part #	Description	Qty.	Part #	Description	Qty.	Part #
A Hose Clamp #48	2	08601	J Screw; M4- .7 X 12, Bttnhd SS	2	07726	S Adapter; Universal, 6" Filter 3.5"	1	21512-1
B Hose; 3" ID X 2" L Reinforced	1	08711	K Hose Clamp #56	2	08620	T Bolt; 5/16"- 18 X 1"L,SS	1	07777
C Intake Tube (HT)	1	087233	L Hose; 3-1/2" ID X 2-1/2" L Hump	1	08699	U Washer; 5/16"ID X 5/8"OD, Flat	1	08276
D Gasket; 3/16 Poron	1	09074	M Washer; 1/4" LOCK, ZN	2	08198	V Bracket; "Z", STL, TK/PC	1	083126
E Vent; Strt 1/2" Hose, 1/4"NPT,	1	080022	N Washer; 1/4"ID X 5/8"OD - SAE	7	08275	W Insert; 5/16-18X.600 ODX.730L	1	088002
F Hose; 1/2" ID X 3-1/2" L	1	087028	O Edge Trim (70")	1	102454	X Hose Clamp #104	1	08697
G Adapter; Mass Air Sensor,	1	09404	P Heat Shield	1	074053	Y Air Filter	1	RF-1042
H Washer; 6MM Flat, SS	2	08269	Q Nut; 6MM Nylock, Hexhead	3	07553			
I Bolt; M6 X 1.00 X 16MM , Bttnhd	6	07730	R Washer; 1" X .300 X .100 Rubber	1	21685			

**NOTE: FAILURE TO FOLLOW INSTALLATION INSTRUCTIONS AND NOT USING THE PROVIDED HARDWARE MAY DAMAGE THE INTAKE TUBE, THROTTLE BODY AND ENGINE.**

#### TO START:

- Turn off the ignition and disconnect the negative battery cable.  
**NOTE: Disconnecting the negative battery cable erases pre-programmed electronic memories. Write down all memory settings before disconnecting the negative battery cable. Some radios will require an anti-theft code to be entered after the battery is reconnected. The anti-theft code is typically supplied with your owner's manual. In the event your vehicles' anti-theft code cannot be recovered, contact an authorized dealership to obtain your vehicles anti-theft code.**



- Release the locking and then disconnect the mass air sensor electrical connector.

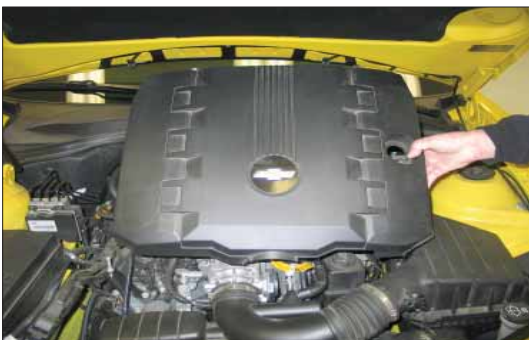

- Remove the oil fill cap and then remove the engine cover from the engine. Reinstall the oil fill cap.



- Disconnect the crank case vent hard line from the 90° connector hose on the factory intake tube.



- Loosen the hose clamp securing the intake tube to the throttle body.



- Remove the two nuts shown securing the factory air box to the inner fender.



- Remove the factory air box assembly from the vehicle.



- Remove the air box mounting grommet shown from the inner fender.  
**NOTE: K&N Engineering, Inc., recommends that customers do not discard factory air intake.**

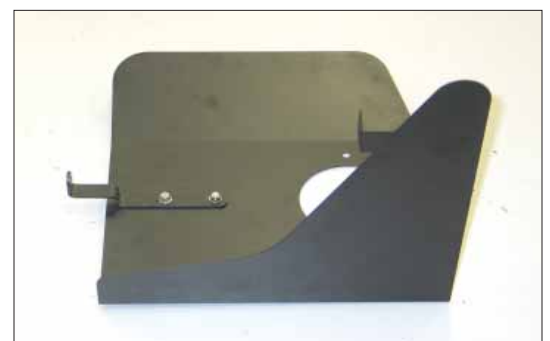

- Install the provided heat shield mounting bracket (083126) onto the heat shield using the hardware provided.

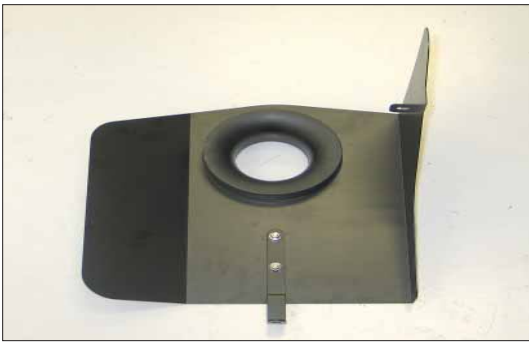

10. Install the filter adapter onto the heat shield and secure with the provided hardware.



11. Install the provided edge trim onto the heat shield as shown.

**NOTE: Some trimming of the edge trim will be necessary.**



12. Install the provided inserted nut onto the heat shield mounting bracket and secure with the provided hardware.

**NOTE: Do not completely tighten at this time.**



13. Install the provided rubber fender washer onto the outward air box mounting stud.



14. Install the heat shield assembly into the vehicle so the inserted nut goes into the air box mounting grommet hole and tab goes onto the air box mounting stud. Secure the heat shield with the provided hardware.



15. Install the provided silicone hose (08711) onto the throttle body and secure with the provided hose clamp.



16. Install the provided silicone hump hose (08699) onto the filter adapter and secure with the provided hose clamp.



17. Install the provided 1/4npt vent fitting into the K&N intake tube as shown.



18. Peel the backing paper off and then install the provided gasket onto the K&N mass air sensor adapter as shown.



19. Remove the mass air sensor mounting screws and then remove the mass air sensor from the factory air box.



20. Install the mass air sensor into the K&N mass air sensor adapter and secure with the provided hardware.

**NOTE: The o-ring gasket provides a very tight seal, be sure the o-ring is seated properly as the mass air sensor is being installed into the adapter.**

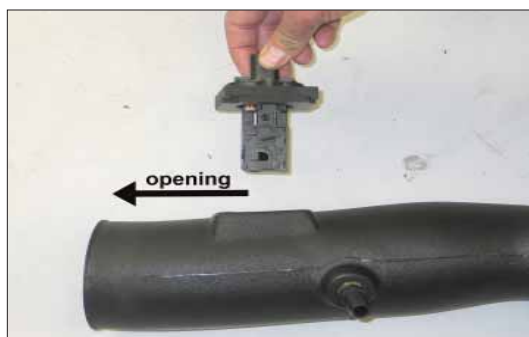

21. Install the mass air sensor assembly into the K&N intake tube so that the opening is towards the filter end of the tube and then secure with the provided hardware.



22. Install the K&N intake tube into the silicone hump hose and then into the silicone hose at the throttle body and secure with the provided hose clamps.



23. Install the provided crank case vent hose onto the factory crank case vent tube and then attach the open end to the vent fitting installed into the K&N intake tube.

**NOTE: Some trimming of the crank case vent hose may be necessary.**



24. Install the K&N air filter onto the filter adapter and secure with the provided hose clamp.



25. Reconnect the mass air sensor electrical connection.



26. Reinstall the engine cover and secure with the oil fill cap.

**NOTE: some minor trimming of the engine cover may be necessary to clear intake tube.**



27. Reconnect the vehicle's negative battery cable. Double check to make sure everything is tight and properly positioned before starting the vehicle.

28. It will be necessary for all K&N® high flow intake systems to be checked periodically for realignment, clearance and tightening of all connections. Failure to follow the above instructions or proper maintenance may void warranty.

**ROAD TESTING:**

1. Start the engine with the transmission in neutral or park, and the parking brake engaged. Listen for air leaks or odd noises. For air leaks secure hoses and connections. For odd noises, find cause and repair before proceeding. This kit will function identically to the factory system except for being louder and much more responsive.
2. Test drive the vehicle. Listen for odd noises or rattles and fix as necessary.
3. If road test is fine, you can now enjoy the added power and performance from your kit.
4. K&N Engineering, Inc., suggests checking the air filter element periodically for excessive dirt build-up. When the element becomes covered in dirt (or once a year), service it according to the instructions on the Recharger® service kit, part number 99-5050 or 99-5000.

**STREET LEGAL IN MOST STATES**

**NOT LEGAL FOR USE IN CA & OTHER STATES  
ADOPTING CA EMISSIONS STANDARDS**

**See our catalog or [knfilters.com](http://knfilters.com) for CARB status on each part for a specific vehicle**

\* FREE K&N® decal To register your warranty, please see us online at [knfilters.com/register](http://knfilters.com/register). FREE K&N® decal \*

• 1455 CITRUS ST., P.O. BOX 1329, RIVERSIDE, CA., U.S.A. 92502 • TECH SERVICE 800-858-3333 • FAX 951-826-4001  
• e-mail: [tech@knfilters.com](mailto:tech@knfilters.com) • WWW: <http://www.knfilters.com>